

ELECTRIC CHAIN HOIST (Single Phase)

Electric Chain Hoists provide a price to quality ratio that is the best in the industry.

Available as hook or trolley mounted.

Features noted with an asterisk (*) come standard in ACI Hoists. Other brands charge up to \$950 for these features.

Standard Features Include:

- Capacity: ¼ to 20 Ton in stock. Higher capacities available upon request.
- Duty Rating: H4
- Heavy duty, wear resistant load chain.
- Upper & lower limit switches cut the power directly to the motor. This safety device is required in hot metal and critical uses.
- Mechanical & electrical brakes.
- Trolley brake, drop lugs and bumpers.
- Sealed body suitable for both indoor and outdoor usage.
- High performance mechanically and electrically interlocked contactor.
- Motorized trolley with side roller system allows for smooth maneuvers through turns.

Lifting Eye*

This is required in many specifications for equipment over 40 pounds.

Overload Limiting Clutch

Prevents overloading of the hoist and protects the hoist from damage.

Easy Maintenance Control Panel

Allows easy access for field maintenance.

Heat Treated Helical & Spur Gears

Precision machined and enclosed in oil bath lubrication, resulting in a quiet, smooth, cool operation and long life.

Forged Carbon Steel Hooks

Under excessive loads, the hook will open gradually and not fracture. Ball bearings produce a smooth rotation. Bottom hook will swivel 360 degrees. Hook latches are standard.

Pendant Control

Easy to use, one handed operation. Rated IP65 standard control voltage is 110V. Strain relief wire is molded to pendant cord for added support.



Heavy Duty Chain Bag*

All of our hoists come with a chain bag at no extra cost.



Load Sheave

Deep groove pockets fully support the load chain during operation. This reduces vibration and chain wear as well as providing a true vertical lift.

Heavy Duty Motor

Increased performance through heavy duty H4 rating as well as standard thermal protection.

Pull-Rotor Motor Brake

An extremely durable and advanced design which contains no brake coil to fail, unlike conventional brakes.



Mechanical Load Brake*

Secondary Weston type mechanical load brake as an added safety feature located inside the gearbox.



Aluminum Body

Die cast aluminum body is light weight with a baked paint finish.

Durable Chain Guide

Provides quiet and smooth guiding of the chain. Easily replaced without disassembly of the hoist. Heavy cast iron construction for improved wear vs. stamped steel design offered by many manufacturers.

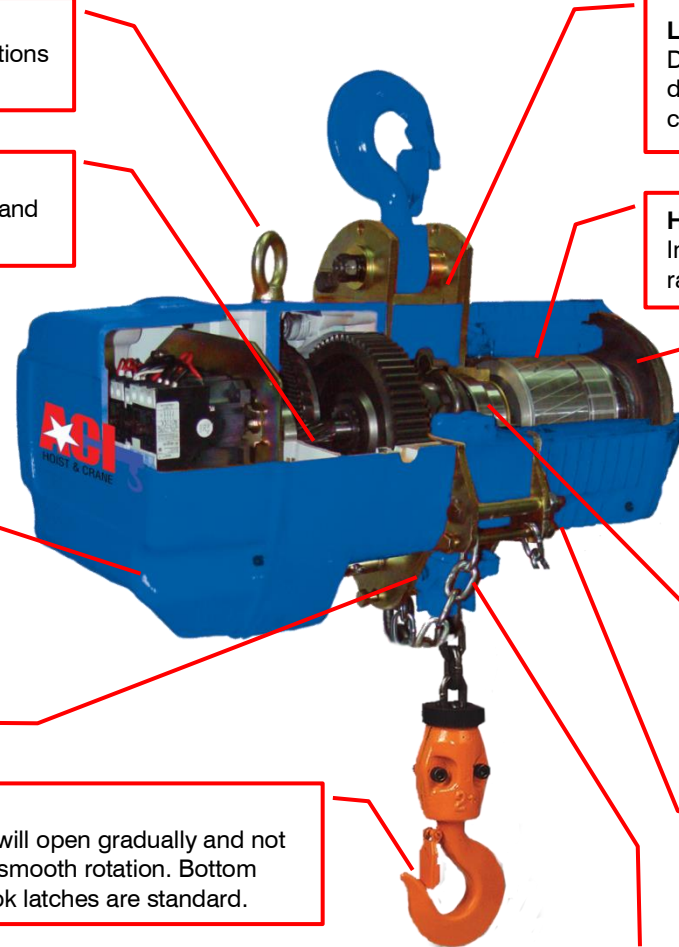

ELECTRIC CHAIN HOIST (Single Phase)

Model SECH

SECH-0214

689 SW 7th Terrace, Dania, FL 33004-3803 | Phone: 954-367-6116

ELECTRIC CHAIN HOIST (Single Phase)



Specifications

Model Number	Capacity (Ton)	Lift Speed (Ft/Min)	Number of Chain Falls	Hoist Motor 1 Phase / 60 Hz		
				HP	Rated Current	
					230 V	
SECHH-00518	1/4	18	1	1.3	11	
SECHH-00526		26		1.3	11	
SECHH-00544		44		2.0	13.5	
SECHH-01018	1/2	18		1.3	11	
SECHH-01026		26		1.3	11	
SECHH-01044		44		2.0	11	
SECHH-02018	1	18		1.3	11	
SECHH-02026		26		2.0	13.5	
SECHH-04026	2	26		5.0	30	
SECHH-04009	2	9		2	1.3	11
SECHH-04013	2	13			2.0	13.5
SECHH-06017	3	17			5.0	30
SECHH-06006		6	3	1.3	11	
SECHH-06009		9		2.0	13.5	
SECHH-10010	5	10	2	5.0	30	
SECHH-15007	7 1/2	7		5.0	30	
SECHH-20010	10	10	4	2 X 5.0	2 X 30	
SECCH-30007	15	7	6			
SECHH-40005	20	5	8			

ELECTRIC CHAIN HOIST (Single Phase)



Low Headroom Motorized Trolley Specifications

Model Number	Capacity (Tons)	Number of Chain Falls	Trolley Motor					
			50 FPM			100 FPM		
			HP	Rated Current		HP	Rated Current	
				230V	460V		230V	460V
MT-020-1	1/4	1	0.5	3.1	1.6	0.5	1.53	0.76
MT-020-1	1/2							
MT-020-1	1							
MT-040-2	2	2	1	1.3	0.68	1	2.13	1.07
MT-040-1		1						
MT-060-3	3	3	1	1.3	0.68	1	2.13	1.07
MT-060-2		2						
MT-100-2	5	2	1	1.3	0.68	1	2.13	1.07

Standard Motorized Trolley Specifications

Model Number	Capacity (Tons)	Number of Chain Falls	Trolley Motor					
			50 FPM			100 FPM		
			HP	Rated Current		HP	Rated Current	
				230V	460V		230V	460V
MT-150-3	7 1/2	3	1	1.34	0.68	1	2.13	1.07
MT-200-4	10	4	2 X 1	2 X 1.34	2 X 0.68	2 X 1	2 X 2.13	2 X 1.07
2 X MT-150-3	15	6						
2 X MT-200-4	20	8	4 X 1	4 X 1.34	4 X 0.68	4 X 1	4 X 2.13	4 X 1.07

ELECTRIC CHAIN HOIST (Single Phase)

Model SECH

SECH-0214

689 SW 7th Terrace, Dania, FL 33004-3803 | Phone: 954-367-6116

ELECTRIC CHAIN HOIST (Single Phase)



Dimensions

1/4 - 7 1/2 Ton Electric Chain Hoist Hook Mounted Dimensions

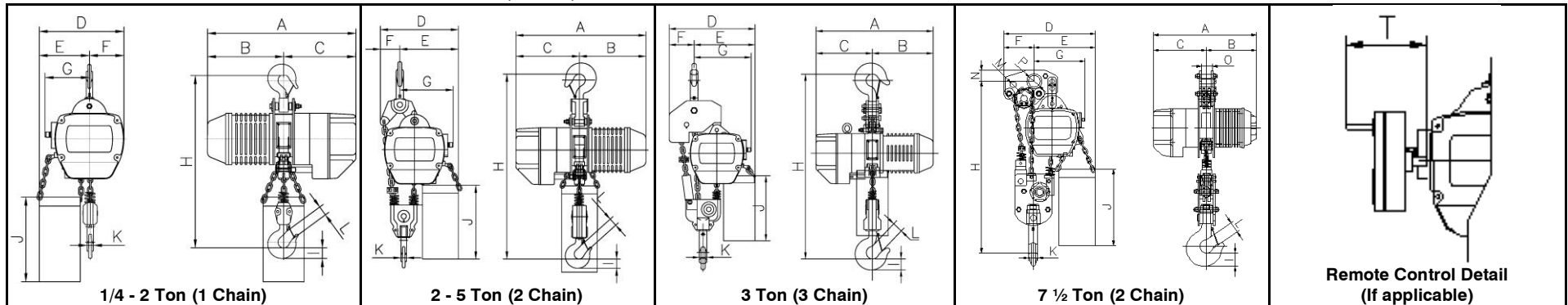

Model Number	H*	D	E*	F	G	I	J*	K	L	O	Approx. Gross Weight w/out Chains (Lbs.)	Single Speed						Variable Frequency Drive									
												A	B	C	G	M	P	T	A	B	C	G	M	P	T		
SECHH-00518	20	11.8	7	4.8	6.3	1.4	11.2	0.9	1.3	---	138	21.75	10.7	11	---	---	---	6	25.25	10.7	14.5	---	---	---	6		
SECHH-00526																											
SECHH-00544																											
SECHH-01018																											
SECHH-01026																											
SECHH-01044																											
SECHH-02018																											
SECHH-02026																											
SECHH-04026	28	16.3	10.25	6.1	7.5	1.6	14	1.23	1.59	---	280	25.5	12	13.5	---	---	---	6	29.75	12	17.75	---	---	---	6		
SECHH-04009	27.6	12.5	9.4	3.2	8.6	1.6	11.2	1.22	1.5	---	155	21.5	10.5	11	---	---	---	6	25	10.5	14.5	---	---	---	6		
SECHH-04013																											
SECHH-06006	31.5	15	10	5	9.5	2	11.2	1.35	1.8	---	240	21.75	10.7	11	---	---	---	6	25.25	10.7	14.5	---	---	---	6		
SECHH-06009																											
SECHH-06017	35	16.5	10	3.5	8.5	2	14	1.35	1.8	---	305	25.5	12	13.5	---	---	---	6	29.75	12	17.75	---	---	---	6		
SECHH-10010	37			4.5		2.5		1.8	2.07		320																
SECHH-15007	38.6	18.5	10.5	7.5	---	3	14.0	2.2	2.8	2.37	480	---	---	---	8.5	1.6	2.94	---	---	---	8.5	1.6	2.8	---	---	---	---

* Dimensions are based on 10ft of lift. All measurements in inches.

ELECTRIC CHAIN HOIST (Single Phase)

Model SECH

SECH-0214

689 SW 7th Terrace, Dania, FL 33004-3803 | Phone: 954-367-6116

ELECTRIC CHAIN HOIST (Single Phase)

10-20 Ton Electric Chain Hoist Dimensions

Model Number	H*	D	E*	F	I	J*	K	L	N	O	Approx. Gross Weight w/out Chains (Lbs.)	Single Speed						Variable Frequency Drive														
												A	B	C	G1/G2	M	P	T	A	B	C	G1/G2	M	P	T							
																								A	B	C	G1/G2	M	P	T		
SECHH-20010	39	35.25	17.62	3.8	14	3.1	2.2	2.9	2.62	2.37	810	25.5	12	13.5	1 / 5	35.6	2.8	6	29.75	12	17.75	1 / 5	35.6	2.8	6							
SECHH-30007	39	2.75	26	20.5	4.4	19.1	3.3	3.6	8.3	2.3	1025				2.87	41	---					49	---	6		29.75	12	17.75	2.8	41	---	6
SECHH-40005	41		33.75	28.3			3.1	4.1			1580				49	49	49															

* Dimensions are based on 10 ft of lift.
 All measurements in inches.
 † Contact us for additional flange width

ELECTRIC CHAIN HOIST (Single Phase)

Model SECH

SECH-0214

689 SW 7th Terrace, Dania, FL 33004-3803 | Phone: 954-367-6116

ELECTRIC CHAIN HOIST (Single Phase)

1/4 - 5 Ton Electric Chain Hoist w/ Standard Push Trolley Dimensions

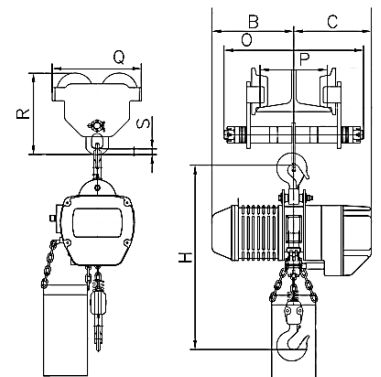

Model Number	H	Q	O	R	S	C	B	P
SECHP-00518	25	8	9.5	8	1.25	11	10.7	1.75 - 5.5
SECHP-00526								
SECHP-00544								
SECHP-01018								
SECHP-01026								
SECHP-01044	7.37							
SECHP-02018	26.25	9.68	12.25	9.25	1.5	13.5	12	2.75 - 8
SECHP-02026								
SECHP-04009	32.7	10.87	12.87	10.35	1.62	11	10.7	3.5 - 8
SECHP-04013								
SECHP-04026								
SECHP-06006	39	13.07	13.5	13	1.62	13.5	12	3.93 - 8
SECHP-06009								
SECHP-06017								
SECHP-10010								
SECHP-10010	42.5	14.87	14	13.86	1.62	13.5	12	4.5 - 8
SECHP-10010								
All dimensions measured in inches. Based on 10 ft of lift.								

ELECTRIC CHAIN HOIST (Single Phase)

Model SECH

SECH-0214

689 SW 7th Terrace, Dania, FL 33004-3803 | Phone: 954-367-6116

ELECTRIC CHAIN HOIST (Single Phase)

1/4 - 5 Ton Electric Chain Hoist w/ Low Headroom Push Trolley Dimensions

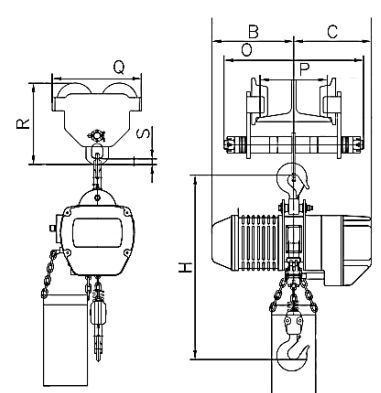

Model Number	H	Q	O	R	S	C	B	P
SECHP-00518	16.5	4.2	0.5	0.5	16.5	11	10.7	3 - 10
SECHP-00526								
SECHP-00544								
SECHP-01018								
SECHP-01026								
SECHP-01044								
SECHP-02018								
SECHP-02026	22				17.3		10.5	
SECHP-04009								
SECHP-04013	24				20	13.5	12	3.75 - 13
SECHP-06006	23				20.7	11	10.7	4 - 10
SECHP-06009								
SECHP-06017	29.75	4.9	0.6	0.6	20	13.5	12	3.75 - 13
SECHP-10010	30.75	5.5			20.5			3.75 - 12.5

All dimensions measured in inches.
Based on 10 ft of lift.

ELECTRIC CHAIN HOIST (Single Phase)

Model SECH

SECH-0214

689 SW 7th Terrace, Dania, FL 33004-3803 | Phone: 954-367-6116

ELECTRIC CHAIN HOIST (Single Phase)



Hoist with Motor Trolley Dimensions

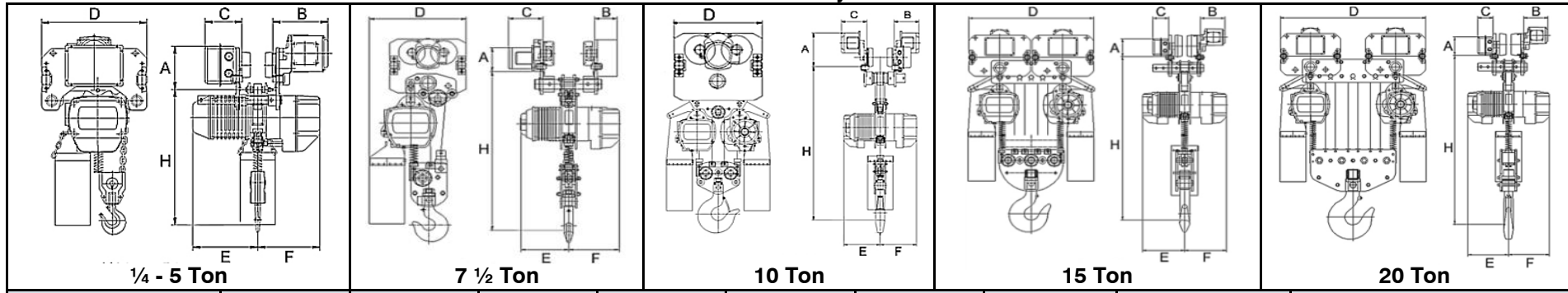

Model Number	H	A	B	C	D	E	F	Flange Width Range	Approx. Gross Weight (Lbs.)
SECHM-00518	16.5	8	8.5	7.75	16.5	10.5	11	3 - 9.5	303.6
SECHM-00526									
SECHM-00544									
SECHM-01018									
SECHM-01026									
SECHM-01044									
SECHM-02018									
SECHM-02026	22	10	8.75	20	12	13.5	4 - 12.5	528.5	
SECHM-04009									
SECHM-04013	23	8	8.5	20.75	10.75	11	5 - 10	477.8	
SECHM-06006									
SECHM-06009	29.75	10	8.75	20	12	13.5	4 - 12.5	593.5	
SECHM-06017									
SECHM-10010	30.75	11	8.75	8	20.5	12	13.5	4-12.5*	652.5
SECHM-15007									
SECHM-20010	43	8	8	6.75	39	12	6 - 12	826.5	
SECHM-30007									
SECHM-40005	45	7	8	6.75	49.25	12	6 - 12	1716.5	
									2773.5

* Can change to 3.75" specification modification.
 All measurements are in inches.
 Based on 10 ft of lift.

ELECTRIC CHAIN HOIST (Single Phase)

Model SECH

SECH-0214

689 SW 7th Terrace, Dania, FL 33004-3803 | Phone: 954-367-6116